

# Bragi

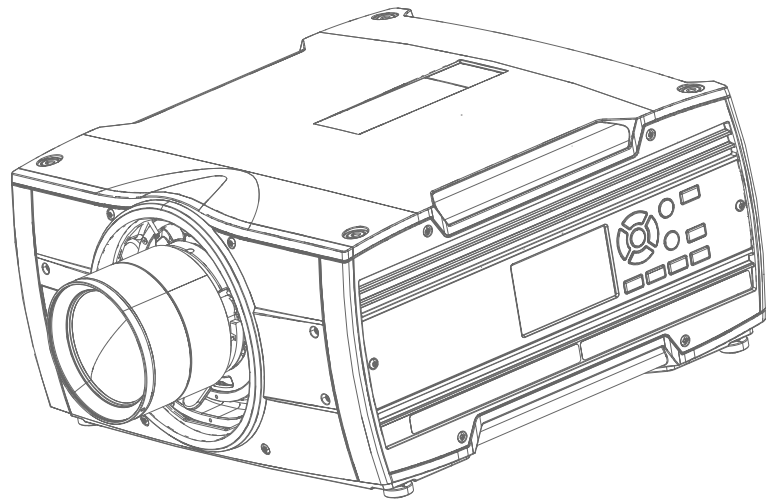

## User Manual

**Barco Fredrikstad AS**

Haborneveien 53, N-1630 Gamle Fredrikstad, Norway  
Support.fre@barco.com  
www.barco.com

**Registered office: Barco NV**

President Kennedypark 35, 8500 Kortrijk, Belgium  
www.barco.com/en/support  
www.barco.com

## Changes

Barco provides this manual 'as is' without warranty of any kind, either expressed or implied, including but not limited to the implied warranties or merchantability and fitness for a particular purpose. Barco may make improvements and/or changes to the product(s) and/or the program(s) described in this publication at any time without notice.

This publication could contain technical inaccuracies or typographical errors. Changes are periodically made to the information in this publication; these changes are incorporated in new editions of this publication.

The latest edition of Barco manuals can be downloaded from the Barco web site [www.barco.com](http://www.barco.com) or from the secured Barco web site <https://www.barco.com/en/signin>.

## Federal Communications Commission (FCC Statement)

This equipment has been tested and found to comply with the limits for a class A digital device, pursuant to Part 15 of the FCC rules. These limits are designed to provide reasonable protection against harmful interference when the equipment is operated in a commercial environment. This equipment generates, uses, and can radiate radio frequency energy and, if not installed and used in accordance with the instruction manual, may cause harmful interference to radio communications. Operation of this equipment in a residential area may cause harmful interference, in which case the user will be responsible for correcting any interference at his own expense.

Changes or modifications not expressly approved by the party responsible for compliance could void the user's authority to operate the equipment.

FCC responsible: Barco Inc.  
3059 Premiere Parkway Suite 400  
30097 Duluth GA, United States  
Tel: +1 678 475 8000

## Trademarks

Brand and product names mentioned in this manual may be trademarks, registered trademarks or copyrights of their respective holders. All brand and product names mentioned in this manual serve as comments or examples and are not to be understood as advertising for the products or their manufacturers.

## Turkey RoHS compliance



■ Türkiye Cumhuriyeti: AEEE Yönetmeliğine Uygundur.

[Republic of Turkey: In conformity with the WEEE Regulation]

## Disposal Information

Waste Electrical and Electronic Equipment



■ This symbol on the product indicates that, under the European Directive 2012/19/EU governing waste from electrical and electronic equipment, this product must not be disposed of with other municipal waste. Please dispose of your waste equipment by handing it over to a designated collection point for the recycling of waste electrical and electronic equipment. To prevent possible harm to the environment or human health from uncontrolled waste disposal, please separate these items from other types of waste and recycle them responsibly to promote the sustainable reuse of material resources.

For more information about recycling of this product, please contact your local city office or your municipal waste disposal service.

For details, please visit the Barco website at: <http://www.barco.com/AboutBarco/weee>

## Disposal of batteries in the product



This product contains batteries covered by the Directive 2006/66/EC which must be collected and disposed of separately from municipal waste.

If the battery contains more than the specified values of lead (Pb), mercury (Hg) or cadmium (Cd), these chemical symbols will appear below the crossed-out wheeled bin symbol.

By participating in separate collection of batteries, you will help to ensure proper disposal and to prevent potential negative effects on the environment and human health.

## Guarantee and Compensation

Barco provides a guarantee relating to perfect manufacturing as part of the legally stipulated terms of guarantee. On receipt, the purchaser must immediately inspect all delivered goods for damage incurred during transport, as well as for material and manufacturing faults Barco must be informed immediately in writing of any complaints.

The period of guarantee begins on the date of transfer of risks, in the case of special systems and software on the date of commissioning, at latest 30 days after the transfer of risks. In the event of justified notice of complaint, Barco can repair the fault or provide a replacement at its own discretion within an appropriate period. If this measure proves to be impossible or unsuccessful, the purchaser can demand a reduction in the purchase price or cancellation of the contract. All other claims, in particular those relating to compensation for direct or indirect damage, and also damage attributed to the operation of software as well as to other services provided by Barco, being a component of the system or independent service, will be deemed invalid provided the damage is not proven to be attributed to the absence of properties guaranteed in writing or due to the intent or gross negligence or part of Barco.

If the purchaser or a third party carries out modifications or repairs on goods delivered by Barco, or if the goods are handled incorrectly, in particular if the systems are operated incorrectly or if, after the transfer of risks, the goods are subject to influences not agreed upon in the contract, all guarantee claims of the purchaser will be rendered invalid. Not included in the guarantee coverage are system failures which are attributed to programs or special electronic circuitry provided by the purchaser, e.g. interfaces. Normal wear as well as normal maintenance are not subject to the guarantee provided by Barco either.

The environmental conditions as well as the servicing and maintenance regulations specified in this manual must be complied with by the customer.

## Copyright ©

All rights reserved. No part of this document may be copied, reproduced or translated. It shall not otherwise be recorded, transmitted or stored in a retrieval system without the prior written consent of Barco.

## Software License Agreement

You should carefully read the following terms and conditions before using this software. Your use of this software indicates your acceptance of this license agreement and warranty.

### Terms and Conditions:

1. No redistribution of the software is allowed.
2. Reverse-Engineering. You may not reverse engineer, decompile, disassemble or alter this software product.

### Disclaimer of Warranty:

This software and the accompanying files are sold "as is" and without warranties as to performance or merchantability or any other warranties whether expressed or implied. In no event shall Barco be liable for damage of any kind, loss of data, loss of profits, business interruption or other pecuniary loss arising directly or indirectly. Any liability of the seller will be exclusively limited to replacement of the product or refund of purchase price.

# Table of contents

<b>1</b>	<b>Safety and environment information</b>	<b>7</b>
1.1	General considerations	8
1.2	Important safety instructions	8
1.3	Safety symbols Bragi	11
1.4	Location of labels	12
1.5	Disposal information	12
1.6	Turkey RoHS compliance	12
1.7	China RoHS compliance	13
1.8	Taiwan RoHS compliance	14
1.9	Contact information	15
1.10	Production Address	15
1.11	Product Info	15
1.12	Statement	15
<b>2</b>	<b>Getting to know the projector</b>	<b>17</b>
2.1	Location of the main exterior components	18
2.2	Service and maintenance	19
2.3	Power on / Standby button backlight indications	19
2.4	LCD Panel	19
2.4.1	LCD panel general	19
2.4.2	LCD touch panel	20
2.4.3	LCD Status screens	20
2.4.4	OSD Menu mode	22
2.4.5	LCD functionality in Ready Mode	22
2.5	Local keypad	22
2.6	Shortcut buttons	23
2.7	Remote control	24
2.7.1	Remote control, battery installation	24
2.7.2	Remote control, protocol setup	25
2.7.3	Functionality overview	26
2.7.4	Remote control, on/off button	27
2.7.5	Function of the RGB filter button	27
2.7.6	Enable / Disable Remote Control	27
2.7.7	Wired RC connection	28
2.8	Projector Address	28
2.8.1	Controlling the projector	29

2.9	Connector panel .....	29
<b>3</b>	<b>Getting the projector started .....</b>	<b>31</b>
3.1	Projector source and control connections.....	32
3.1.1	Input source connections.....	32
3.1.2	Connector Specifications.....	32
3.1.2.1	DVI-I .....	32
3.1.2.2	Display Port 1.2.....	32
3.1.2.3	HDMI 2.0.....	33
3.1.2.4	HDBase T .....	33
3.1.3	Control Interfaces.....	34
3.1.3.1	RS-232.....	34
3.1.3.2	LAN/Ethernet.....	34
3.1.3.3	USB-A port.....	35
3.2	Power up the projector.....	35
3.3	Power down the projector .....	35
3.4	Power mode transitions.....	36
3.4.1	General .....	36
3.4.2	Power on projector .....	36
3.4.3	Going from READY to ON.....	36
3.4.4	Going from ON to READY .....	37
3.4.5	Going from READY to ECO standby.....	37
3.4.6	Going from ECO to ON .....	37
3.4.7	Wake On LAN (WOL) .....	37
3.5	Power modes .....	37
3.6	Customize projector settings.....	37
3.7	User interface.....	38
3.7.1	On Screen Display (OSD).....	38
<b>4</b>	<b>GUI – Profiles .....</b>	<b>41</b>
4.1	Profiles introduction.....	42
4.2	Profiles setup parameters .....	42
4.3	Create new profile .....	43
<b>5</b>	<b>Upgrade projector firmware.....</b>	<b>47</b>
5.1	Upgrade procedure.....	48
<b>6</b>	<b>User maintenance — Cleaning the projector .....</b>	<b>49</b>
6.1	Projector lenses.....	50
6.2	Projector cabinet .....	50
	<b>Index .....</b>	<b>51</b>

# Safety and environment information

# 1

## About

Read this chapter thoroughly before attempting to install or operate the projector.

To prevent personal injury to users or physical damage to the projector while installing and using your projector, ensure that you understand and follow all safety guidelines, instructions and warnings included in this chapter and this manual.

## Clarification of the term Bragi series used in this document

Use in this document of the term, Bragi , means that the content is applicable for the following products:

- Bragi CS

## Defining the Bragi platform

The Bragi series products in general, are all products within the Barco GP5 platform

## 1.1 General considerations

### Notice on optical radiation from the Bragi projectors

- Do not stare into Beam.
- This projector is Risk Group 2 (RG2) according to IEC EN 62471-5.
- Any operation or adjustment not specifically instructed by the user's guide creates the risk of hazardous light radiation exposure.
- Do not open or disassemble the projector as this may cause danger to unauthorized personnel

### General safety instructions

- This product contains no user serviceable parts.  
Attempts to modify/replace mechanics or electronics inside the housing or compartments will violate any warranties and may be hazardous.
- Do not stare into beam when the projector is on. The bright light may result in permanent eye damage.
- Before operating this equipment please read this manual thoroughly and retain it for future reference.
- Installation and preliminary adjustments should be performed by properly trained and qualified personnel.
- All warnings on the projector and in the documentation manuals must be adhered to.
- All instructions for operating and use of this equipment must be followed precisely.
- All local installation codes should be adhered to.

### Notice on safety

This equipment is built in accordance with the requirements of the international safety standards IEC60950-1, as basis for National safety regulation world wide. The safety standard covers information technology equipment including electrical business equipment intended to operate in "normal" environments (offices and homes). This safety standard imposes important requirements on the use of safety critical components, materials and insulation, in order to protect the user or operator against risk of electric shock and energy hazard and having access to live parts. Safety standards also impose limits to the internal and external temperature rises, radiation levels, mechanical stability and strength, enclosure construction and protection against the risk of fire. Simulated single fault condition testing reduce the risk of hazards and contribute to ensure the safety of the equipment to the user even when the equipment's normal operation fails.

### Users definition

Throughout this manual, the term SERVICE PERSONNEL refers to Barco authorized persons having appropriate technical training and experience necessary to be knowledgeable of potential hazards to which they are exposed (including, but not limited to HIGH VOLTAGE ELECTRIC and ELECTRONIC CIRCUITRY and HIGH BRIGHTNESS PROJECTORS) in performing a task, and of measures to minimize the potential risk to themselves or other persons. Only Barco authorized SERVICE PERSONNEL, knowledgeable of such risks, are allowed to perform service functions inside the product enclosure. The term USER and OPERATOR refers to any person other than SERVICE PERSONNEL.

## 1.2 Important safety instructions

### To prevent the risk of electrical shock

- This product should be operated from a mono phase AC power source.
- This apparatus must be grounded (earthed) via the supplied 3 conductor AC power cable. If none of the supplied power cables are the correct one, consult your dealer.  
If you are unable to insert the plug into the outlet, contact your electrician to replace your obsolete outlet. Do not defeat the purpose of the grounding-type plug.  
Never use 2- wire power cords, as this is dangerous and could lead to electrical shock. Always use a power connector with a ground terminal.
- Do not allow anything to rest on the power cord. Do not locate this product where persons will walk on the cord. To disconnect the cord, pull it out by the plug. Never pull the cord itself.
- Ensure that the main power cord complies with the national regulations at the site where the equipment is used.
- Do not use unauthorized replacements



- Do not operate the projector with a damaged cord. Replace the cord.  
Do not operate the projector if the projector has been dropped or damaged - until it has been examined and approved for operation by a qualified service technician.
- Position the cord so that it will not be tripped over, pulled, or contact hot surfaces.
- If an extension cord is necessary, a cord with a current rating at least equal to that of the projector should be used. A cord rated for less amperage than the projector may overheat.
- Never push objects of any kind into this product through cabinet slots as they may touch dangerous voltage points or short out parts that could result in a risk of fire or electrical shock.
- Make sure that no objects enter into the vents and openings of the set.
- Do not expose this projector to rain or moisture.
- The projector is designed for indoor use only. Never operate the unit outdoors.
- Do not immerse or expose this projector in water or other liquids.
- Do not spill liquid of any kind on this projector.
- Should any liquid or solid object fall into the cabinet, unplug the set and have it checked by qualified service personnel before resuming operations.
- Do not disassemble this projector, always take it to an authorized trained service person when service or repair work is required.
- Do not use an accessory attachment which is not recommended by the manufacturer.
- Lightning - For added protection for this video product during a lightning storm, or when it is left unattended and unused for long periods of time, unplug it from the wall outlet. This will prevent damage to the device due to lightning and AC power-line surges.

### To prevent personal injury

- To prevent injury and physical damage, always read this manual and all labels on the system before connecting to the wall outlet or adjusting the projector.
- To prevent injury, take note of the weight of the projector.
- To prevent injury, ensure that the lens and all covers are correctly installed. See installation procedures.
- Warning: high intensity light beam. NEVER look into the lens! High luminance could result in damage to the eye.
- Always switch off the projector and disconnect from the mains power supply before attempting to remove any of the projector covers or access parts inside the projector.
- This product contains no user serviceable parts. Attempts to modify/replace mechanics or electronics inside the housing or compartments will violate any warranties and may be hazardous.
- Do not place this equipment on an unstable cart, stand, or table. The product may fall, causing serious damage to it and possible injury to the user.
- Only place the projector on a stable surface, or mount it securely using an approved ceiling-mount.

### To prevent fire hazard

- Barco projection products are designed and manufactured to meet the most stringent safety regulations. This projector radiates heat on its external surfaces and from ventilation ducts during normal operation, which is both normal and safe. Exposing flammable or combustible materials into close proximity of this projector could result in the spontaneous ignition of that material, resulting in a fire. For this reason, it is absolutely necessary to leave an "exclusion zone" around all external surfaces of the projector whereby no flammable or combustible materials are present.
- Do not place flammable or combustible materials near the projector!
- Caution! Hot air is exhausted from the rear vent. Do not place objects that are sensitive to heat nearer than 25 cm (10") to the exhaust vent.
- Slots and openings in this equipment are provided for ventilation. To ensure reliable operation of the projector and to protect it from overheating, these openings must not be blocked or covered.
- The openings should never be blocked by placing the projector too close to walls, or other similar surface. Allow for sufficient distance to walls and ceilings to avoid overheating. Minimum safety distance to the exhaust area of the unit must not be less than 25 cm (10") and to the intake area, not less than 25 cm (10").
- This projector should never be placed near or over a radiator or heat register.
- This projector should not be placed in a built-in installation or enclosure unless proper ventilation is provided.
- Do not cover the projector or the lens with any material while the projector is in operation. Keep flammable and combustible materials away from the projector at all times.

- Mount the projector in a well-ventilated area away from sources of ignition and out of direct sun light. Always allow ample airflow through the projector.
- Never expose the projector to rain or moisture. In the event of fire, use sand, CO2 or dry powder fire extinguishers.
- Never use water on an electrical fire.
- Always have service performed on this projector by authorized Barco service personnel. Always insist on genuine Barco replacement parts. Never use non-Barco replacement parts as they may degrade the safety of this projector.
- Projection rooms must be well ventilated or cooled in order to avoid heat buildup.
- Let the projector cool down completely before storing. Remove cord from the projector when storing.

### To prevent projector damage

- To ensure correct airflow is maintained, the projector should only be operated when all of its covers in place. The exception from this is the front cover, that can be removed to give access to multiple anchor points. See User Guide for more detailed info regarding this issue.
- Always remove lens cap before switching on the projector. If the lens cap is not removed, it may melt due to the high energy light emitted through the lens. Melting the lens cap may permanently damage the surface of the projection lens
- Only connect the projector to signal sources and voltages as described in the technical specification. Connecting to unspecified signal sources or voltages may lead to malfunction and permanent damage of the unit.
- To ensure correct airflow is maintained, it should only be operated when all of its covers are in place.
- The projector must always be installed in a manner which ensures free flow of air into its air inlets and unimpeded evacuation of the hot air from its cooling system.
- Slots and openings in the cabinet are provided for ventilation. To ensure reliable operation of the product and to protect it from overheating, these openings must not be blocked or covered. The openings should never be blocked by placing the product on a bed, sofa, rug, or other similar surface. This product should never be placed near or over a radiator or heat register. The device should not be placed in a built-in installation or enclosure unless proper ventilation is provided. Ensure that nothing can be spilled on, or dropped inside the projector. If this does happen, switch off and unplug the mains supply immediately. Do not operate the projector again until it has been checked by Barco authorized service personnel.
- Do not block the projector cooling fans or free air movement around the projector. Minimum safety distance to the exhaust area of the unit must not be less than 25 cm (10") and to the intake area, not less than 25 cm (10").
- Do not use this equipment near water.
- Do not operate the projector outside its temperature and humidity specifications as this may result in overheating and malfunction.
- Never place the projector in direct sun light. Sun light on the lens can severely damage the Digital Mirror Devices™ in which case there is a loss of warranty.
- Save the original shipping carton and packing material. They will come in handy if you ever have to ship your equipment. For maximum protection, repack your set as it was originally packed at the factory.
- Unplug this product from the wall outlet before cleaning. Do not use liquid cleaners or aerosol cleaners. Use a damp cloth for cleaning. Never use strong solvents, such as thinner or benzene, or abrasive cleaners, since these will damage the cabinet. Stubborn stains may be removed with a cloth lightly dampened with mild detergent solution.
- To ensure the highest optical performance and resolution, the projection lenses are specially treated with an anti-reflective coating, therefore, avoid touching the lens. To remove dust on the lens, use a soft dry cloth. Do not use a damp cloth, detergent solution, or thinner.





### On servicing

- Do not attempt to service this product yourself, as opening or removing covers may expose you to dangerous voltage potentials and risk of electric shock.
- Refer all servicing to Barco authorized repair centers.
- Attempts to alter the factory-set internal controls or to change other control settings not specially discussed in this manual can lead to permanent damage to the projector and cancellation of the warranty.
- Unplug this product from the wall outlet and refer servicing to Barco authorized service personnel or technicians under the following conditions:
  - If liquid has been spilled into the equipment.
  - If the product has been exposed to rain or water.

- If the product does not operate normally when the operating instructions are followed. Adjust only those controls that are covered by the operating instructions since improper adjustment of the other controls may result in damage and will often require extensive work by a qualified technician to restore the product to normal operation.
- If the product has been dropped or the cabinet has been damaged.
- If the product exhibits a distinct change in performance, indicating a need for service.
- When the power cord or plug is damaged or frayed.
- Replacement parts: When replacement parts are required, be sure the service technician has used original Barco replacement parts. Unauthorized substitutions may result in degraded performance and reliability, fire, electric shock or other hazards. Unauthorized substitutions may void warranty.
- Safety check: Upon completion of any service or repairs to this projector, ask the service technician to perform safety checks to determine that the product is in proper operating condition.

### 1.3 Safety symbols Bragi

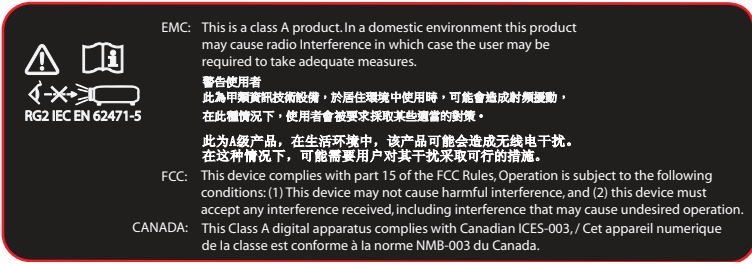
Description of safety symbols used in product documentation or on product.

Image	Description
	<p>Refer to user manual for further information!</p>
	<p>Caution! Do not stare into beam, RG2 product.</p>
	<p>No telephone! Do not connect to telephone lines.</p>
 <p>EMC: This is a class A product. In a domestic environment this product may cause radio Interference in which case the user may be required to take adequate measures.</p> <p>警告使用者 此為A類資訊技術設備，於居住環境中使用時，可能會造成射頻擾動，在此種情況下，使用者會被要求採取某些適當的對策。</p> <p>此为A级产品，在生活环境中，该产品可能会造成无线电干扰。在这种情况下，可能需要用户对干扰采取可行的措施。</p> <p>FCC: This device complies with part 15 of the FCC Rules, Operation is subject to the following conditions: (1) This device may not cause harmful interference, and (2) this device must accept any interference received, including interference that may cause undesired operation.</p> <p>CANADA: This Class A digital apparatus complies with Canadian ICES-003./ Cet appareil numérique de la classe est conforme à la norme NMB-003 du Canada.</p>	<p>EMC Label</p>
	<p>RG2 Label</p>

## 1.4 Location of labels

### Label positions

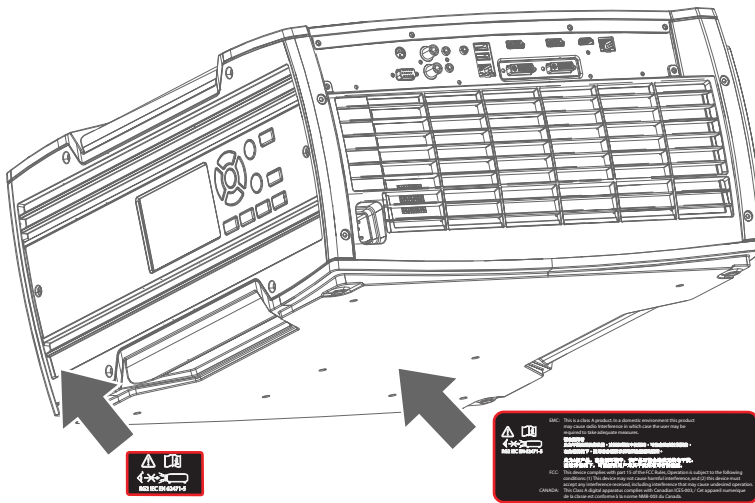

Image 1-1 Location of RG2 and EMC label.

## 1.5 Disposal information

### Disposal Information

Waste Electrical and Electronic Equipment



■ This symbol on the product indicates that, under the European Directive 2012/19/EU governing waste from electrical and electronic equipment, this product must not be disposed of with other municipal waste. Please dispose of your waste equipment by handing it over to a designated collection point for the recycling of waste electrical and electronic equipment. To prevent possible harm to the environment or human health from uncontrolled waste disposal, please separate these items from other types of waste and recycle them responsibly to promote the sustainable reuse of material resources.

For more information about recycling of this product, please contact your local city office or your municipal waste disposal service.

For details, please visit the Barco website at: <http://www.barco.com/AboutBarco/weee>

### WEEE Information

This product conforms to all requirements of the EU Directive on waste electrical and electronic equipment (WEEE). This product shall be recycled properly. It can be disassembled to facilitate proper recycling of its individual parts.

Consult your dealer or relevant public authority regarding drop-off points for collection of WEEE. For details, please visit the Barco website at: <http://www.barco.com/en/AboutBarco/weee>.

## 1.6 Turkey RoHS compliance

### Turkey RoHS compliance



■ Türkiye Cumhuriyeti: AEEE Yönetmeliğine Uygundur.

[Republic of Turkey: In conformity with the WEEE Regulation]

## 1.7 China RoHS compliance

### 中国大陆 RoHS (Information for China ROHS compliance)

根据中国大陆《电器电子产品有害物质限制使用管理办法》（也称为中国大陆RoHS），以下部分列出了Barco产品中可能包含的有毒和/或有害物质的名称和含量。中国大陆RoHS指令包含在中国信息产业部MCV标准：“电子信息产品中有毒物质的限量要求”中。

According to the “Management Methods for the Restriction of the Use of Hazardous Substances in Electrical and Electronic Products” (Also called RoHS of Chinese Mainland), the table below lists the names and contents of toxic and/or hazardous substances that Barco’s product may contain. The RoHS of Chinese Mainland is included in the MCV standard of the Ministry of Information Industry of China, in the section “Limit Requirements of toxic substances in Electronic Information Products”.

零件项目(名称) Component name	有毒有害物质或元素 Hazardous substances and elements					
	铅 (Pb)	汞 (Hg)	镉 (Cd)	六价铬 (Cr6+)	多溴联苯 (PBB)	多溴二苯 醚 (PBDE)
印制电路配件 Printed Circuit Assemblies	X	O	X	O	O	O
外接电(线)缆 External Cables	X	O	O	O	O	O
内部线路 Internal wiring	X	O	O	O	O	O
镜头支架 Lensholder	X	O	O	O	O	O
螺帽,螺钉(栓),螺旋(钉),垫圈,紧固件 Nuts, bolts, screws, washers, Fasteners	X	O	O	O	O	O
电源供应器 Power Supply Unit	X	O	O	O	O	O
风扇 Fan	X	O	O	O	O	O
附電池遙控器 Remote control	X	O	O	O	O	O

本表格依据SJ/T 11364的规定编制

This table is prepared in accordance with the provisions of SJ/T 11364.

O: 表示该有毒有害物质在该部件所有均质材料中的含量均在 GB/T 26572 标准规定的限量要求以下。

O: Indicates that this toxic or hazardous substance contained in all of the homogeneous materials for this part is below the limit requirement in GB/T 26572.

X: 表示该有毒有害物质至少在该部件的某一均质材料中的含量超出 GB/T 26572 标准规定的限量要求。

X: Indicates that this toxic or hazardous substance contained in at least one of the homogeneous materials used for this part is above the limit requirement in GB/T 26572.



在中国大陆销售的相应电子信息产品（EIP）都必须遵照中国大陆《电子电气产品有害物质限制使用标识要求》标准贴上环保使用期限（EFUP）标签。Barco产品所采用的EFUP标签（请参阅实例，徽标内部的编号使用于指定产品）基于中国大陆的《电子信息产品环保使用期限通则》标准。

All Electronic Information Products (EIP) that are sold within Chinese Mainland must comply with the “Marking for the restriction of the use of hazardous substances in electrical and electronic product” of Chinese Mainland, marked with the Environmental Friendly Use Period (EFUP) logo. The number inside the EFUP logo that Barco uses (please refer to the photo) is based on the “General guidelines of environment-friendly use period of electronic information products” of Chinese Mainland.

## 1.8 Taiwan RoHS compliance

### 限用物質含有情況標示聲明書 (Declaration of the Presence Condition of the Restricted Substances Marking)

單元 Unit	限用物質及其化學符號 Restricted substances and its chemical symbols					
	鉛 Lead (Pb)	汞 Mercury (Hg)	鎘 Cadmium (Cd)	六價鉻 Hexavalent chromium (Cr6+)	多溴聯苯 Polybrominated biphenyls (PBB)	多溴二苯醚 Polybrominated diphenyl ethers (PBDE)
印製電路板配件 Printed Circuit Assemblies	—	○	—	○	○	○
外接電 (線) 纜 External Cables	—	○	○	○	○	○
內部線路 Internal wiring	—	○	○	○	○	○
鏡頭支架 Lensholder	—	○	○	○	○	○
螺絲組件 Nuts, bolts, screws, washers, Fasteners	—	○	○	○	○	○
電源供應器 Power Supply Unit	—	○	○	○	○	○
風扇 Fan	—	○	○	○	○	○
遙控器 Remote control	—	○	○	○	○	○
<p>備考1. “超出0.1 wt %” 及 “超出0.01 wt %” 係指限用物質之百分比含量超出百分比含量基準值。                      Note 1 : “Exceeding 0.1 wt %” and “exceeding 0.01 wt %” indicate that the percentage content of the restricted substance exceeds the reference percentage value of presence condition.</p> <p>備考2. “○” 係指該項限用物質之百分比含量未超出百分比含量基準值。                      Note 2 : “○” indicates that the percentage content of the restricted substance does not exceed the percentage of reference value of presence.</p> <p>備考3. “—” 係指該項限用物質為排除項目。                      Note 3 : The “—” indicates that the restricted substance corresponds to the exemption.</p>						

備註: 此RoHS表格適用於以下產品型號: GP5

Hint: This RoHS table is suitable for following models: GP5

## 1.9 Contact information

### Barco contact information

**Registered office address:** President Kennedypark 35, 8500 Kortrijk, Belgium

**Contact address:** Beneluxpark 21, 8500 Kortrijk, Belgium

#### Contact address (for Taiwan) :

公司名稱 (Company Name) : 巴可股份有限公司

地址 (Address) : 新北市板橋區新站路16號33樓

傳真 (Fax) : 02-7715 0298

電話 (Tel) : 02-7715 0299

E-mail : service.taiwan@barco.com

### Importers contact information

To find your local importer, contact Barco directly or one of Barco's regional offices via the contact information given on Barco's web site, [www.barco.com](http://www.barco.com).

### Contact information Norway factory

Barco Fredrikstad as

Habornveien 53, N1630 Gamle Fredrikstad, Norway

Phone: +476930 4550

**Support:**Support.fre@barco.com

## 1.10 Production Address

### Factories

#### Barco NV (BELGIUM)

President Kennedypark 35 , B-8500 Kortrijk

## 1.11 Product Info

### Product info



Image 1-2

product name 產品名稱:

projector 投影機

model 型號: GP5

## 1.12 Statement

### EN55032/CISPR32 Class A MME (MultiMedia Equipment)

Warning : This equipment is compliant with Class A of CISPR 32. In a residential environment this equipment may cause radio interference.

### **Class A ITE (Information Technology Equipment)**

Warning : This is a class A product. In a domestic environment this product may cause radio interference in which case the user may be required to take adequate measures.

警告使用者: 此為甲類資訊技術設備，於居住環境中使用時，可能會造成射頻擾動，在此種情況下，使用者會被要求採取某些適當的對策。



# Getting to know the projector.

# 2

2.1	Location of the main exterior components .....	18
2.2	Service and maintenance .....	19
2.3	Power on / Standby button backlight indications .....	19
2.4	LCD Panel .....	19
2.5	Local keypad .....	22
2.6	Shortcut buttons .....	23
2.7	Remote control .....	24
2.8	Projector Address .....	28
2.9	Connector panel .....	29

## 2.1 Location of the main exterior components.

### Defining of surfaces

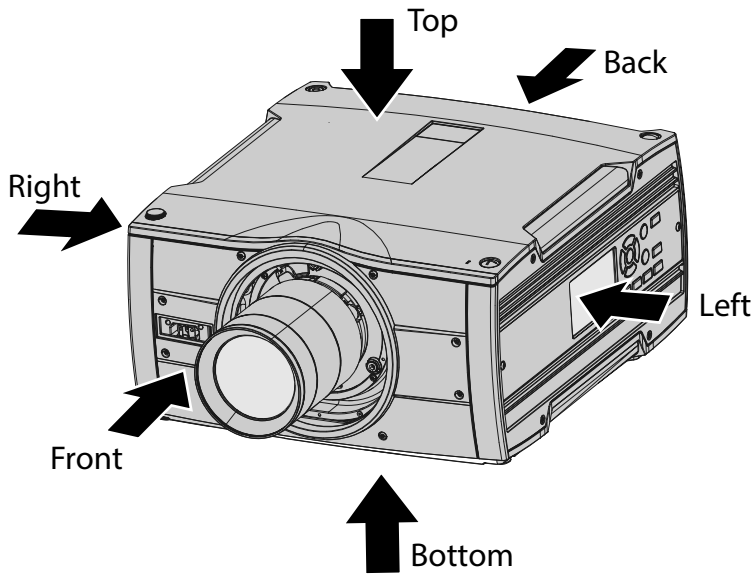

Image 2-1

### Main Components

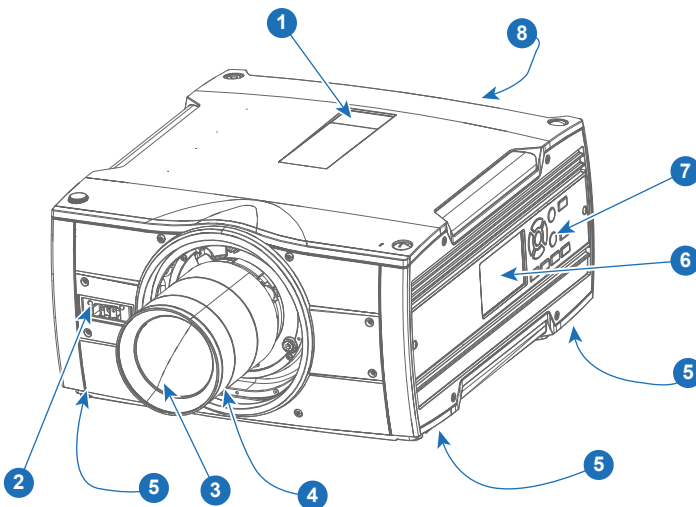

Image 2-2

Main exterior components matrix			
Item Number	Component	Item Number	Component
1	IR Receiver top	5	Projector feet (x4)
2	IR Receiver front	6	LCD Panel
3	Lens	7	Key Pad
4	Lens release handle	8	Back Panel / Connectors

## 2.2 Service and maintenance

### General

The Bragi projector does not have any user serviceable parts.

All service tasks must only be carried out by the manufacturer, or a Barco authorized service personnel or Barco technicians.

## 2.3 Power on / Standby button backlight indications

### Indicator

In addition to the LED indicator, the projector also displays status indications in the backlight of the Power / Standby button.

The table below shows the details regarding this indications.

Operating Status	Indication Color / Behavior
On (active)	Blue
Wait on	Blue flashing
Standby (off)	White
Wait	White short flashing
Overheating	Red flashing
Configure/upgrade	White fast flashing
Standby ECO	White heartbeat
Software Lockup	Red
Severe errors	Red Flashing



When severe errors occur, the failure description will always be available in the notification page in the status menu.

## 2.4 LCD Panel

### 2.4.1 LCD panel general

#### About

The LCD panel (See chapter 2.6, Local Keypad) is located on the right side of the projector, and has two modes of indication; Mirror of the OSD, and Information display.

Toggle between the two indications by using the Menu button on the keypad, or on the remote control

1. When mirroring the OSD, the LCD showing the menus and adjustment information.
2. When in information mode, showing this Information regarding the status of the projector:
  - Projector status
  - Network address and status
  - Active source
  - Illumination Status
  - Current firmware version
  - Active functions (Enabled Functions).
  - Display Info, including Transport delay

Getting to know the projector.

- Environment Info.

Use the navigation keys (arrows) to scroll the information menu.

The time before the LCD display fades out is user configurable, see “”;

## 2.4.2 LCD touch panel



The LCD menus can occasionally be slightly different in layout compared with the OSD menu, due to a more optimal layout regarding to the touch functionality of the LCD.

### LCD touch panel functionality

In addition to the remote control and the keypad, it is also possible to navigate in the menus with the touch functionality in the LCD panel.

Press the icons to select the functions.

Select switches to toggle.

Select and drag sliders to adjust slider value.

## 2.4.3 LCD Status screens

### Disclaimer on GUI images used in this manual

The GUI images in this manual are example illustrations and should be treated as such. While the name of the projector displayed in the illustrations may be different from the projector model you are currently using, the menu lay-out and functionality is identical.

### About

When in information mode, shift between the different pages by using the left or right arrows on the keypad or the remote control. The different pages contain different information, shown in the figures below.

While the projector menu is not active, or the projector is Ready or Standby mode, the Status screens remain visible. These screens give an overview of the state of the projector and can be navigated through using the left and right arrow keys, or by swiping the screen left or right. The status screens are the following:

- **Dashboard:** The main overview. This screen displays all the chosen options on the projector (chosen source, blending/masking, display mode, etc).
- **About:** General info about the projector. This includes serial number, software version, mounted lens and light source runtime.
- **Notifications:** The error and/or warning messages that are currently active. If no messages are active, this list will be empty.
- **Preview:** A preview pane of the projected image. If no image is being projected, a test image is displayed instead.

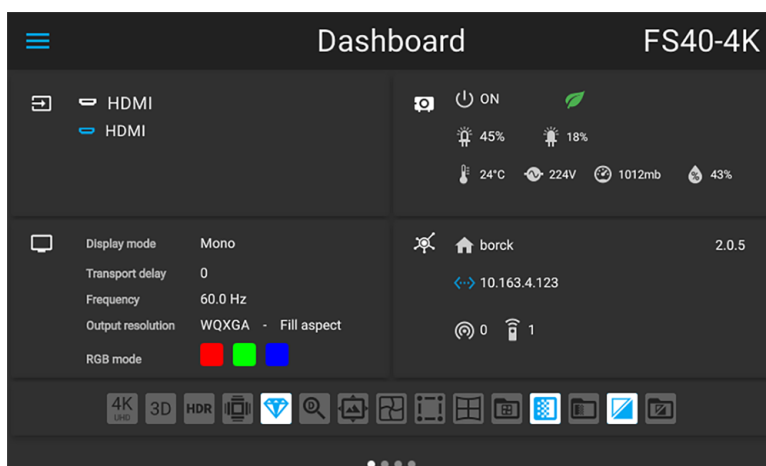

Image 2-3 Dashboard page

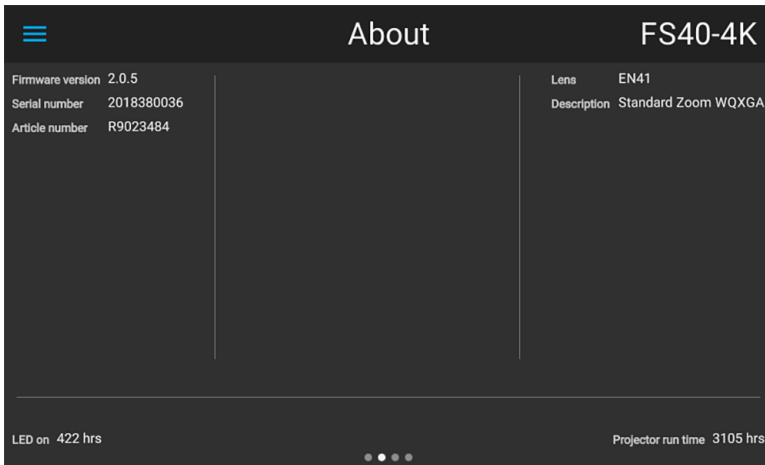

Image 2-4 About page

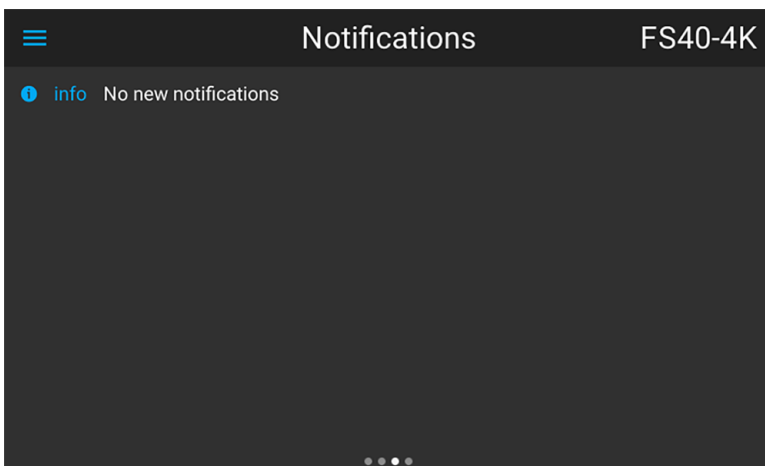

Image 2-5 Notifications page



Image 2-6 Preview page

### Mirroring the source input. (Preview page).

This page in the information mode is useful for verifying the input signal connection without switching the projector (light source on).

This function shows the output of the currently active source on the LCD panel. The source content should be a picture without warp and blend applied. The picture will be limited by the LCD resolution, 800x480pixels.



The projector performance will drop when the LCD monitoring the input, due to use of resources. Exit the input monitoring when not in use.

## 2.4.4 OSD Menu mode

### About.

This is the projector setup menus, explained in detail in their own chapters in this manual. (Source menu, Image menu, Installation menu, System Settings menu, Status menu).

## 2.4.5 LCD functionality in Ready Mode

When the projector is in Ready mode, it is possible to activate and navigate in the projectors menu on the LCD display, in order to set or check values and settings before the lamp is switched on.

Ready mode is enabled either when the power cable is connected (after the startup sequence), or when pressing the Power Off for 4 seconds when the projector is in On mode. See chapter 5.4 Power Mode Transitions for a graphic presentation of the ready mode.

### Procedure

When in ready mode, press the Menu button either on the remote control, or the keypad to enter the menus. Navigate by using the arrow and OK keys, either on the remote control or the keypad.

## 2.5 Local keypad

### About

The Keypad gives direct access to several functions, in addition to access to the menu system. The keypad and remote control functions are equal.

The keypad has a back light that can be switched on and off manually. The light turns off automatically after a preset time.

The Standby key is equipped with white, blue and red backlight depending on the status of the projector. See table in “Power on / Standby button backlight indications”, page 19 for info regarding this.

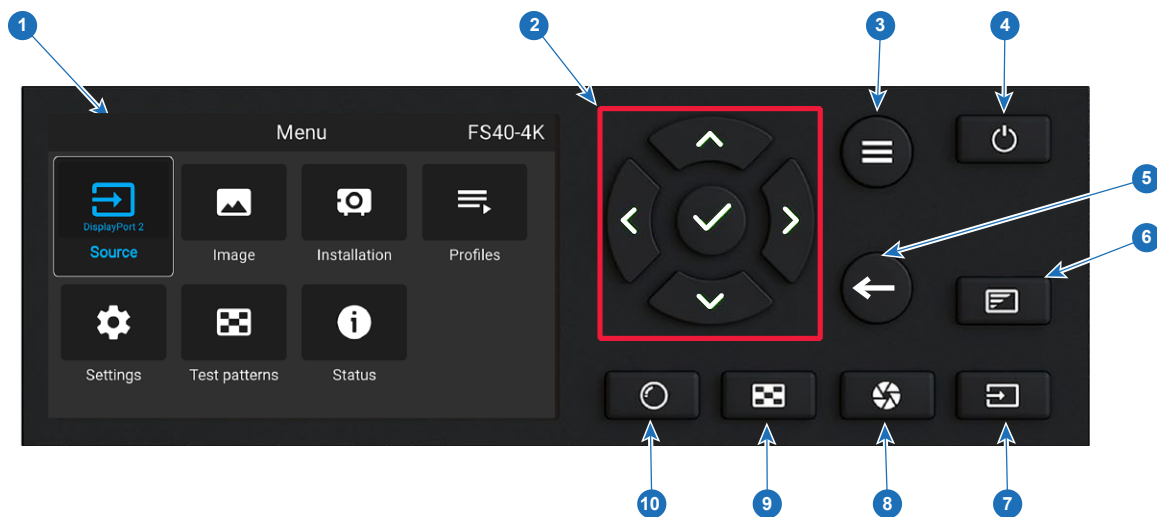

Image 2-7

Item No.	Name	Description
1	LCD Display	Shows navigation menu incl. sub menus and projector status screens (dashboard, notification, about and preview).
2	Navigation keys	Navigation arrows (up, down, left, right), confirm selection (✓)
3	Menu button	Toggle between OSD / Information menu.

Item No.	Name	Description
4	Power button	Power on / standby / ready
5	Back	Back to previous screen.
6	OSD ON/OFF	Deactivate the On Screen Display (OSD). Only critical warnings will be displayed.
7	Input	Shortcut to input source menu on LCD. Use navigation keys to select and enable input.
8	Shutter	Enable and disable the lens shutter function. This is not a mechanical shutter, but it toggles the light source on and off. Backlight is red when the shutter are enabled.
9	Test Patterns	Shortcut to test pattern menu on LCD. Use navigation keys to select the desired pattern.
10	Lens	Shortcut to lens function. A test pattern displays on the OSD. LCD screen displays the navigation keys to manage and confirm actions.

## 2.6 Shortcut buttons

### About the keypad shortcut buttons

On the keypad, there are three shortcut buttons; for lens function, test pattern selection, and input selection. See [“Local keypad”, page 22](#) and [“Remote control”, page 24](#) for location and description. (The remote control has only the test pattern shortcut button).

When the test pattern or input shortcut button is pressed, a pop up menu will show up on the LCD screen.

Make a selection by the arrow keys, and confirm.

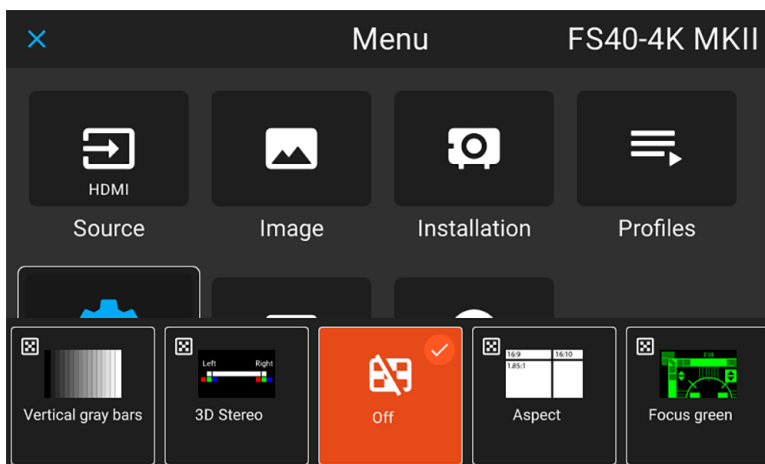

Image 2-8 Test pattern pop up menu

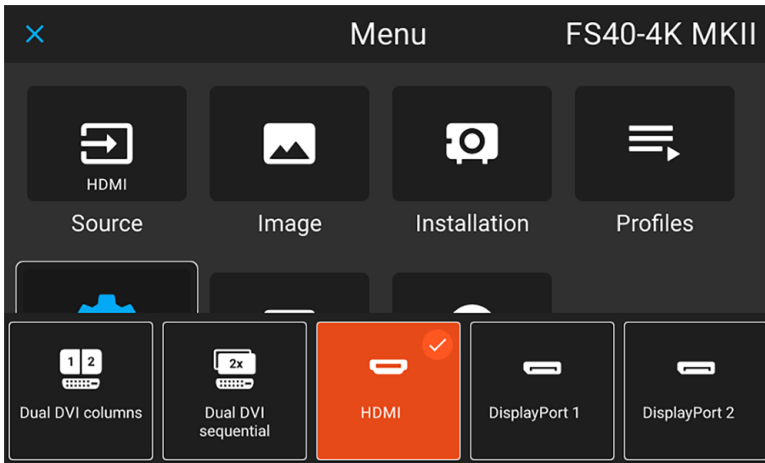

Image 2-9 Input source pop up menu

## 2.7 Remote control

### 2.7.1 Remote control, battery installation

#### Where to find the batteries for the remote control ?

The batteries are not placed in the remote control unit to avoid control operation in its package, resulting in a shorter battery life time. At delivery the batteries can be found in a separated bag attached to the remote control unit. Before using your remote control, install the batteries first.

#### How to install

1. Push the battery cover tab with the fingernail a little backwards (1) and pull, at the same time, the cover upwards (2).

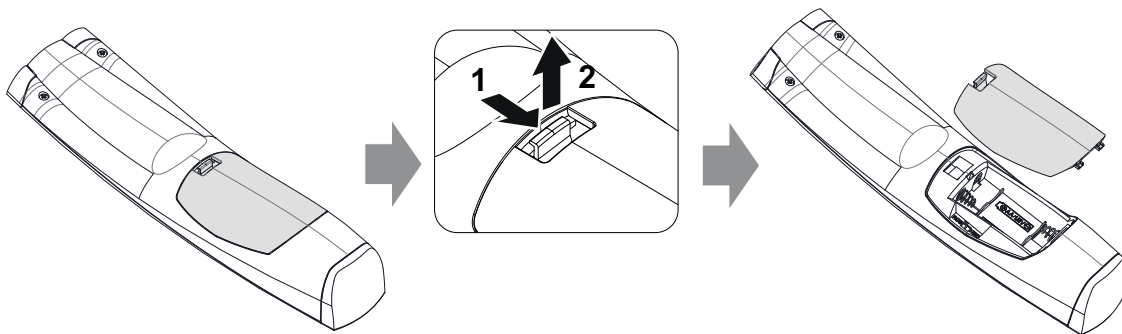

Image 2-10

2. Insert the two AA size batteries, making sure the polarities match the + and - marks inside the battery compartment.



*Tip:* Use alkaline batteries for optimum range and life time.



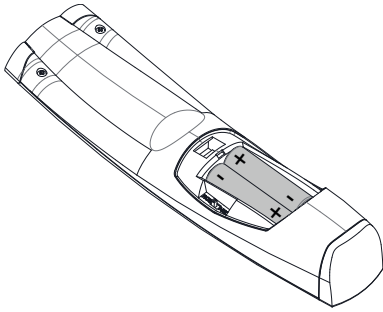

Image 2-11

3. Insert (1) both lower tabs of the battery cover in the gaps at the bottom of the remote control, and press (2) the cover until it clicks in place.

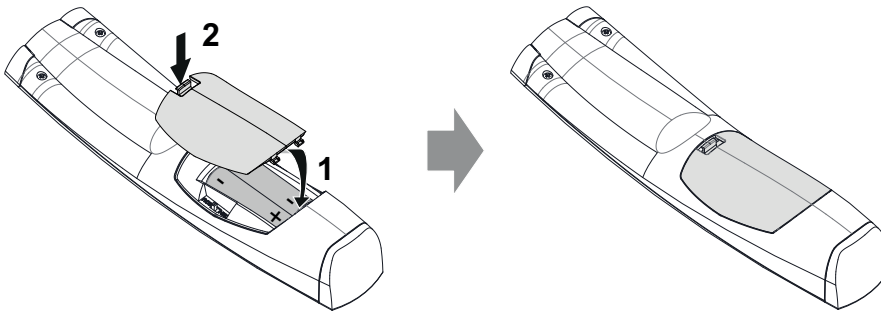

Image 2-12



When replacing batteries, the broadcast address of the RCU will be reset to its default value '0'.



**CAUTION:** Replace with the correct battery type. Use two AA size batteries

## 2.7.2 Remote control, protocol setup

### About the used protocol

The protocol is the code send out by the remote control when a button is pressed. Depending on this code, the projector can decode the signals. The remote control can be used with two different protocols, RC5 and NEC. Depending on the projector to control, the remote control can be switched between these protocols.

### Which protocol to use

- The **NEC** protocol have to be used for Barco projectors based on the Pulse platform: Loki, Balder, F40, F70, F80, F90, HDX 4K, UDX, UDM and more..
- The **RC5** protocol have to be use all other Barco projectors: HDX W, HDF W, HDQ 2K, ...

### How to set

1. Remove the cover. For more info on how to remove, see "[Remote control, battery installation](#)", page 24.
2. Place the switch in the NEC position.

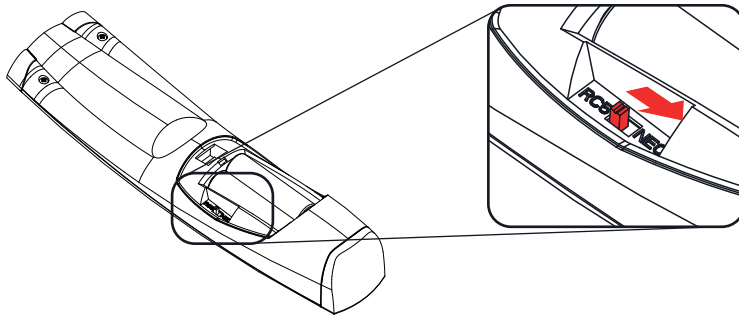

Image 2-13

### Remark with RC5 protocol

Not all buttons of the Pulse RCU are one-to-one compatible with the legacy Barco RCU. Button pairs SHUTTER open/close and POWER on/off emit the same code (per pair) when in RC5 mode, because the legacy RCU's only had 1 button for Shutter and 1 button for Standby.

## 2.7.3 Functionality overview

### Remote Control Unit buttons

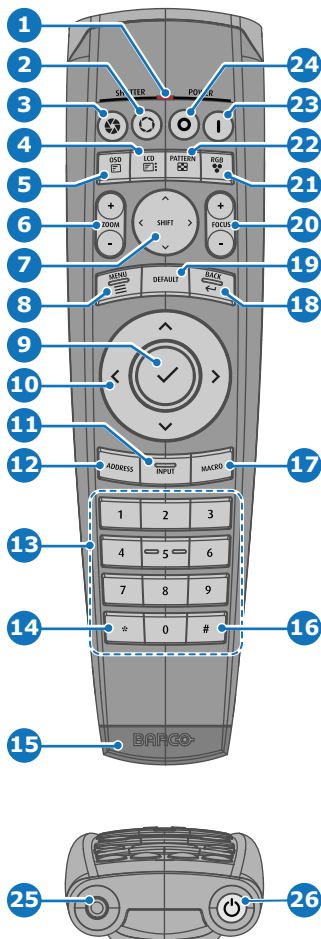

- 1 Button pressed indicator.
- 2 Shutter Open.
- 3 Shutter Close.
- 4 Touch Panel On/Off. (Not in use).
- 5 OSD On/Off.
- 6 Lens Zoom.
- 7 Lens Shift.
- 8 Menu Activation.
- 9 Menu Selection, OK button.
- 10 Menu Navigation.
- 11 Input Selection.
- 12 Address button.
- 13 Numeric buttons.
- 14 Backspace (while entering values)
- 15 XLR connector.
- 16 Decimal mark (while entering values)
- 17 Macro button. (Not in use)
- 18 Menu Back.
- 19 Default button. (Not in use).
- 20 Lens Focus.
- 21 RGB Button.
- 22 Test Patterns.
- 23 Power On.
- 24 Power Off.
- 25 Stereo Jack.
- 26 RCU On/Off.

The projector remote control is a full feature wireless remote control, powered by two (2) standard AA batteries. The battery compartment is on the back side of the remote control.

The remote control is backlit for use in dark environments. It also has an Jack connector for wired connection to the projector. When the wire is connected, the IR beam is switched off.

## 2.7.4 Remote control, on/off button

### Purpose of the remote control on/off button

The Pulse remote control unit has at the front side an on/off switch (reference 1 [Image 2–14](#)). Switching off the remote control prevents that unwanted commands are sent due to an accidental key press. Furthermore, switching the RCU off will extend the battery life time of the remote control.

To activate the remote control press the on/off button.

To deactivate the remote control press the on/off button again.

Default when (re)placing batteries, is “ON”.

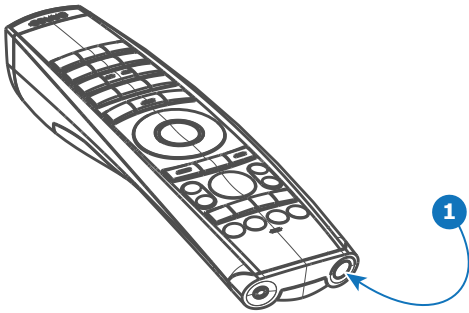

Image 2–14

## 2.7.5 Function of the RGB filter button

### Filtering the color of the projected image

By pressing the RGB filter button on the RCU you can place a color filter on the output of the projector. This feature can be useful during the installation and configuration of a multi-projector or multi-channel setup. By having one projector project a red image and another project a green image, it is easier to spot and adjust the overlap section.

By pressing this button multiple times, you will have different active filters, in the following cycle:

- Red + Green + Blue (default)
- Red only
- Green only
- Blue only
- Red + Green
- Green + Blue
- Red + Blue
- Red + Green + Blue
- etc



After powering up, the colors will always revert back to full RGB.

## 2.7.6 Enable / Disable Remote Control

### About

This function is for disabling the IR sensors for the remote control. Either front or rear, or both.

Select the menu path *Settings/Communication/IR control*



Image 2-15



When all sensors are turned off, the projector will not receive any signals from the remote control. To enable the sensors again, use the keypad on the projector.

Select which sensors to be disabled.

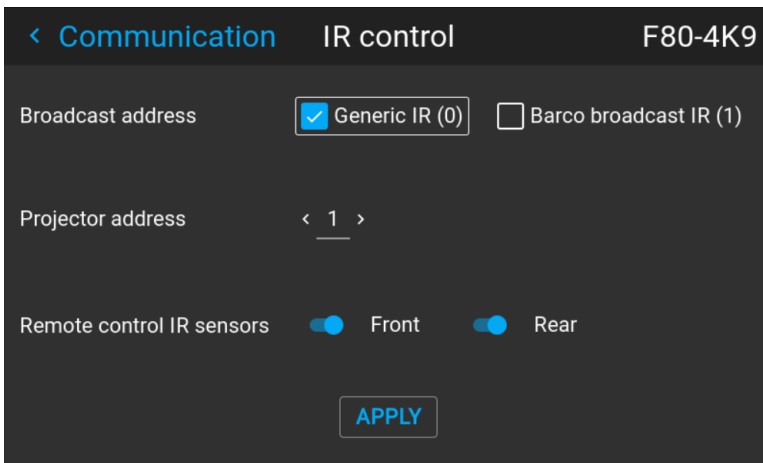

Image 2-16

Enter the Apply button to confirm the action

## 2.7.7 Wired RC connection

### About

The remote control can also be directly wired to the projector from the stereo jack connector on the remote, (See [“Functionality overview”, page 26](#) ), to the RC connector on the back panel of the projector. (See section [“Connector Panel”](#))

In this mode, the projector will not be affected by signals from other non-wired remote controls.

When using wired remote control, the broadcast address must be set to “Generic ID (0)”. See the menu in [“Enable / Disable Remote Control”, page 27](#).

It is not possible to program the remote control in wired mode. (Directly connected, no sense in programming).

## 2.8 Projector Address



### Projector address

Address installed in the projector to be individually controlled.



### Broadcast address

Projector will always execute the command coming from a RCU programmed with that broadcast address.

## 2.8.1 Controlling the projector

### Why a projector address?

As more than one projector can be installed in a room, each projector should be separately addressable with an RCU or computer. Therefore each projector has its own address.

### Set up an individual Projector Address

The set up of a projector address can be done via the software.

### Projector controlling

When the address is set, the projector can be controlled now:

- with the RCU: only for addresses between 1 and 31.

### Broadcast Address

Every projector has a broadcast (common) address '0' or '1'. The default address is '0'.

The choice between '0' and '1' can be selected in the GUI: “System Settings” → “Communication” → “IR Control”.



Placing new batteries in the remote control or plugging the remote to a projector via a cable will automatically reset the address back to its default value '0'.

## 2.9 Connector panel

### General

The source input panel is located at the back of the projector. For source specifications, see table below.

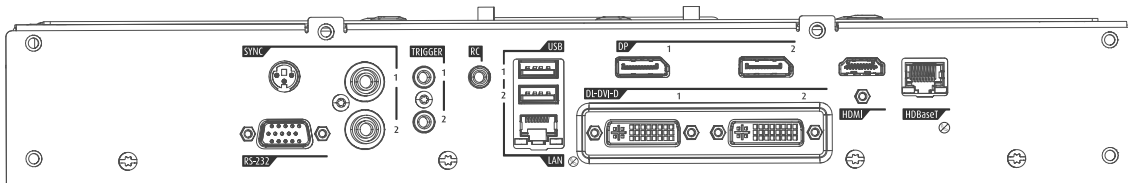
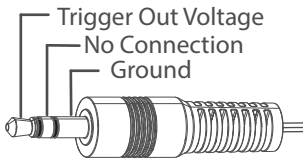

Image 2-17

Name	Pcs	Description	Purpose
RS-232	1	9-pin DB9 connector	For Projector Control. Allows for wired remote control and monitoring of many projector functions used in installation environments
Sync	3	BNC Sync Port IN/OUT; Bidirectional mini-DIN (1x 3D sync Out, and 2x Sync In/Out)	For Projector Control This is mainly used in multiple projector installations with requirement of synchronization between the units
Trigger	2	12VDC - 0,5A (6W) 	For Controlling Peripherals, like motorized screens, curtains etc. Give 12V output when activated. See API manual for activation info. <b>NOTE Disconnect the projector power cable before connecting or removing the trigger cable</b>
RC	1	Jack connector for wired remote	For Projector Control
USB	2	USB 2.0 type A, 4 pin	For Software upgrade
LAN	1	Standard RJ45 connector	For Projector Control

<b>Name</b>	<b>Pcs</b>	<b>Description</b>	<b>Purpose</b>
DP	2	Standard display port	For Projector Input
DL-DVI-D	2	Dual DVI-I 1.0 (DVI_D Functionality).	For Projector Input. These connectors can also be used to form one uniform image by feeding half of the image into each connector. HDCP compliant for sources up 165 Mhz
HDMI	1	Standard HDMI 2.0	For Projector Input
HDBaseT	1	Standard RJ45 8P8C Connector	For Projector Input

# Getting the projector started

# 3

3.1	Projector source and control connections .....	32
3.2	Power up the projector .....	35
3.3	Power down the projector .....	35
3.4	Power mode transitions .....	36
3.5	Power modes .....	37
3.6	Customize projector settings .....	37
3.7	User interface .....	38

## 3.1 Projector source and control connections

### 3.1.1 Input source connections



The source switching time is variable and could take few seconds..

#### Source signal connectivity

The connector panel at the back of the projector is used for all source connections.

Source signal connectivity on the projector is:

- 2x Dual Link DVI-I (DVI-D functionality)
- 2x DisplayPort 1.2
- 1x HDMI 2.0
- 1x HDBaseT

### 3.1.2 Connector Specifications

#### 3.1.2.1 DVI-I

##### Specifications

Parameter	Value
Connector	DVI-I female digital RGB
Signal characteristics	DVI 1.0, Digital, TMDS
Max. cable length	25 m (24 AWG)
Max. pixel rate	330 MHz (dual link), 165 Mhz (single link)
Scan format	Progressive
Max. input data resolution	1920x1200 60Hz (Single link), 2560x1600 60Hz (Dual Link), 1920x1200 120 Hz (Dual Link), 1920x2400 @60Hz
Bit depth	8 bit
EDID	Supported
HDCP	Supported

#### 3.1.2.2 Display Port 1.2

##### Specifications

Parameter	Value
Connector	Standard Display port
Signal characteristics	DP 1.2
Functionality	Mandatory
Max. cable length	2 m (24 AWG) - RBR; 2 m (24 AWG) – HBR1, HBR2
Supported Link Rate	RBR, HBR1, HBR2
Scan format	Progressive



Parameter	Value
Max. input data resolution	2560x1600@120Hz WQXGA / 3840x2400 @60Hz (4K ) Max
Bit depth	8, 10, 12 bit
EDID	Supported
HDCP	Supported

### 3.1.2.3 HDMI 2.0

#### Specifications



Regarding HDMI 2.0: The decryption protocol HDCP 2.2 are enabled and valid in this unit.

Parameter	Value
Connector	Standard HDMI
Signal characteristics	Digital, TMDS
Max. cable length	2 m (24 AWG)
Max. pixel rate	594MHz
Max. input data resolution	3840x2160 @60Hz
Bit depth	8, 10, 12 bits
EDID	Supported
HDCP	Supported
Ethernet	No
Audio return	No
HDCP	Supported

### 3.1.2.4 HDBase T



The HDBaseT standard allows the link to also be used as a regular network port. In addition to carrying video data, it can also be connected to regular ethernet network without carry out any video data.

Due to limitations in the projector and network standards, only the LAN and the HDBaseT should be used for network traffic, but not both simultaneously. If both are connected simultaneously it might lead to undefined behavior where traffic is not being sent on the link indicated by the IPaddress.

This is only valid when the projector has a firmware version 2.1 or higher installed.

#### Specifications

Parameter	Value
Reference specification	HDBaseT 1.0 Specification, June 2010
Connector	Standard RJ-45, 8P8C
Signal characteristics	HDBaseT
Max. cable length (1080p/48b/60Hz)	100 m (Cat5e/6), Pixel Clock <=225MHz, Video Datarate <=5.3Gbps 70 m (Cat5e/6), Pixel Clock >225MHz, Video Datarate >5.3Gbps 100 m (Cat6a/7), Pixel Clock >225MHz, Video Datarate >5.3Gbps

Parameter	Value
Max TMDS Clock Frequency	270 MHz
Max video resolution supported	4096x2160 @30Hz
HDCP Pass-Through	Yes, from Source to Projector
IR Extension	Not Supported
RS-232 Extension	Not Supported
10/100Mbps Ethernet Pass-Through	Not Supported
Fallback to 100BaseTx, IEEE 802.3u	Not Supported
USB Over Centre Tap	Not Supported
Power Over Ethernet	Not Supported
Audio	Not Supported
LEDs - HD Base Status	Operation: Green, Left Link/Mode: Yellow, Right

### 3.1.3 Control Interfaces



The HDBaseT input can also be used as a regular network port. See [“Connector Specifications”, page 32](#), HDBaseT specification.

#### HDBaseT as network input

##### About

The following control interfaces are available on the projector:

- 1x RS-232 (for projector control)
- 1x LAN/Ethernet (for projector control)
- 2x USB-A ports

##### 3.1.3.1 RS-232

##### Specifications

Parameter	Value
RS-232 connector	1 female DB9 connector (RS232-in) for projector control and debug

##### 3.1.3.2 LAN/Ethernet

##### Specifications

Parameter	Value
Ethernet connector	1 RJ45 Connector for projector control (not content)
Protocols	DHCP, TCP/IP, UDP/P
Speed	10/100 Mbit/1000Mbit

### 3.1.3.3 USB-A port

#### Specifications

Parameter	Value
USB connector	Type A
Function	Firmware upgrade using USB sticks
Power	Power 5V, max 1,5A (out)
Standard	USB 2.0

## 3.2 Power up the projector



**CAUTION:** Sources should always be connected before the projector is powered up



**CAUTION:** Ensure that the main power cord complies with the national regulations where the equipment is used.

Do not use unauthorized replacements.  
Do not use power cords which are damaged.

#### Power up the projector using the keypad or remote

1. Connect the line cord to the projector.
2. Plug the 3-pronged cord into a grounded AC outlet.  
The projector will begin warming up, and the backlight of the Standby /power button are flashing white.
3. When the backlight on the standby button are constant white, the projector are in standby mode, ready to be switched on.
4. Press the standby button on the keypad or the power button on the remote to bring the projector up to on mode.  
The power button backlight on the keypad will flash blue while the projector is warming up.
5. When the power button backlight is steady blue, the projector is ready for use.

## 3.3 Power down the projector

#### Power down using the keypad or remote

1. Depress and hold the power button on the keypad or remote for four (4) seconds.  
The Projector is now in cooling down phase.
2. Wait 2 minutes before disconnecting the power cord. (If disconnecting is required).



**WARNING:**

There is a risk of reducing the expected lifetime of the projectors DMD device if the power cord is removed too early, due to the device's shutdown sequence.

## 3.4 Power mode transitions

### 3.4.1 General

#### Transition Diagram

This diagram shows all modes available on the projector (unplug, ON, READY, ECO), and the actions necessary to change mode.

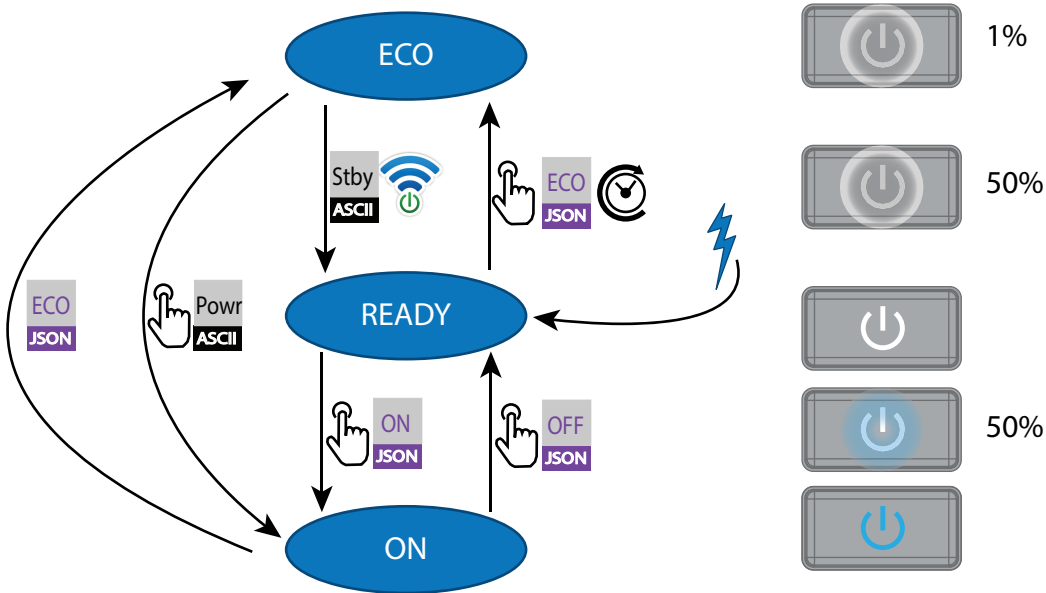





Image 3-1

-  Projector mains powered
-  Auto transition after x minutes if ECO mode enables
-  Press power On/Off button, remote On/Off button

### 3.4.2 Power on projector



If not already connected, connect the female side of the power cord with the power input socket of the projector. For more details see section dedicated to the power cord installation.

#### Description

Plug the 3-prong plug of power cord into a grounded AC outlet. The projector will go to **READY** mode. During this stage the system boots and performs the internal check of the boards. The *Power On/Off button* will BLINKING WHITE until **READY** mode is achieved. Once in **READY** mode, the *Power On/Off button* will be lit WHITE.

### 3.4.3 Going from READY to ON

#### Description

Press the *Power On/Off button* on the projector, or the *Power On* button on the remote control. The projector will power **ON**. The *Power On/Off button* will BLINK BLUE during the transition from **READY** to **ON**. Once the projector is on, the *Power On/Off button* will be lit BLUE.

### 3.4.4 Going from ON to READY

#### Description

Press and hold the *Power on/off* button on the projector for 4 seconds, or press the *Power Off* button on the remote control. The projector will power down through a cool down phase. The *Power on/off* button will BLINK WHITE during the transition from **ON** to **READY**. Once the projector is in **READY**, the *Power on/off* button will be lit WHITE.

### 3.4.5 Going from READY to ECO standby

#### Description

If ECO Standby mode is enabled in the service menu (refer to the section "GUI - system settings/Standby ECO", in User Guide) the projector will automatically go to **ECO** standby mode after a time-out (default 15 minutes). All electronics (including fans, pumps,...) go down except for a very small wake up controller. The *Power on/off* button will FLASH WHITE every second.

### 3.4.6 Going from ECO to ON

#### Description

Press the *Power on/off* button on the projector, or the *Power On* button on the remote control. The projector goes from **ECO** directly to **ON**. The projector will go through the same booting phase as on power plugging, then do the transition from **READY** to **ON**. Of course startup-time will be longer then from **READY** to **ON**.

### 3.4.7 Wake On LAN (WOL)

#### About

The projector has WOL functionality, that can be used for the projector to go from ECO mode to READY mode. Use a json command for transition from READY to ON.

The WOL is performed by sending a Magic Packet followed by the projectors MAC address. The MAC address is found in the *Menu / Settings / Communication / LAN*. menu. The MAC address is similar to the HW address that is shown in this menu path.



The LAN cable must be connected when the projector enter the ECO mode, in order to obtain the Wake on LAN function.

## 3.5 Power modes

#### General

The table below details the projector power modes.

Mode	Description
Normal	Projector is booted up and the light source is on
Ready	Projector is booted up but the light source is off
ECO Standby	Light source is switched off and projector electronics are powered down

## 3.6 Customize projector settings

#### About

The projector display, behavior and user interface can be adjusted to meet individual requirements.

Options include: *Menu/Settings/Themes*

- Adjust the OSD menu color

## 3.7 User interface

### 3.7.1 On Screen Display (OSD)

#### About

The projector on screen display (OSD) is the primary user interface (UI). From here, you can review and adjust all projector and display settings.

The OSD interface uses tabs to display the main menu. Topics are then further sorted and displayed by function: main (topic) — sub (function) — sub (function).

There are seven main menu tabs: Source, Image, Installation, Profiles, Settings, Test pattern and Status.

The OSD can be disabled by pressing the OSD on/off button.



In order to show the OSD, the OSD On/Off button must be disabled. (White backlight on the button). When the button have blue illumination, the OSD will not appear, and the display information are only visible on the LCD Display. Only Critical warnings will be displayed.

#### User access levels

The projector's software platform uses access levels to define what each user can do.

There are two user access levels: Standard User and Power User. In addition, there is a Service user access for certified Service personnel.

A standard user has access to all projector functionality and OSD menu items. A power user has, in addition to access to all projector functionality and OSD menu items, access to a number of advanced functions. Access to power user features is password-protected. Contact your projector supplier for more information.

#### Navigation

You can navigate the OSD using the local keypad or the remote control.

Press the MENU button to display the OSD. (The OSD must be enabled, press OSD button to enable.)

Use the arrow keys to navigate left, right, up and down.

Press the OK button to select a menu topic and get more options.

Use the numeral keys to enter values, or use the arrow keys to move the barscale up or down.

Press MENU again to exit the menu system.

Press the OSD button to deactivate the OSD on the screen. Only critical warnings will be displayed.



Some menu options are reserved for Power or Service Users; these will be grayed out and not available for selection when in standard user mode. To access these features, enter your Power or Service Code in the Service Menu or contact your support representative for more information.

#### Define values

Menu settings are displayed using checkboxes, barscale sliders, and selection boxes, depending on the type of menu.

To set a value:

- Press OK to select or deselect a checkbox (turn a function ON or OFF).
- Use the arrow keys to move the barscale slider up or down on the value line. For a barscale 0-9, each step will equal 10% of the total value.
- To enter the value as a direct number, press ENTER, input the digit(s), and then Press ENTER again to execute and exit cursor mode e.g. ENTER 79 ENTER.

Changes to values are implemented dynamically.

## **Menu memory**

The OSD menu remembers the last selected sub-item as long as the projector is running. The menu memory is reset when restarting the projector from standby.





# GUI – Profiles

# 4

4.1	Profiles introduction .....	42
4.2	Profiles setup parameters.....	42
4.3	Create new profile .....	43

## 4.1 Profiles introduction

### About Profiles

The Profile function make it possible to store different profiles / projector setups for different use cases, and quickly recall them when needed. This means that there is not necessary to enter a lot of different menus to adjust the projector setup for different user cases.

As examples of different user cases are setup for video, gaming, different viewing environments and so on.

This is useful in installations where the projector are used for different purposes.

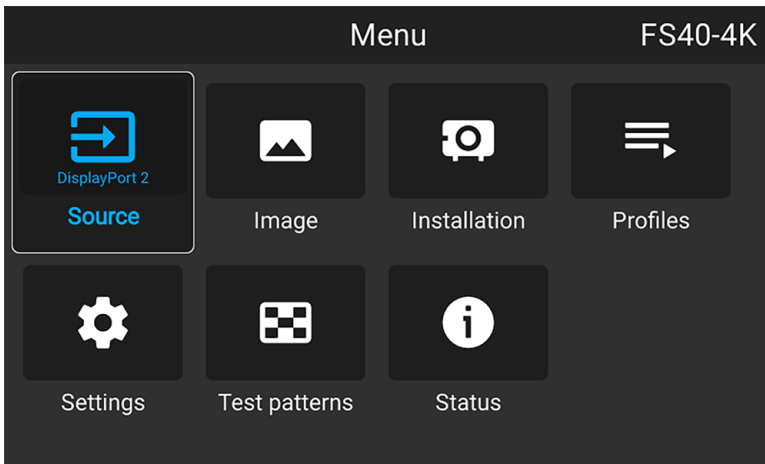

Image 4-1

## 4.2 Profiles setup parameters

### Available profile settings

Area of interest	Settings
Source	Currently selected source
Image	<ul style="list-style-type: none"> <li>Brightness</li> <li>Contrast</li> <li>Gamma (Value and type)</li> <li>Intensity</li> <li>Saturation</li> <li>Sharpness</li> <li>Output resolution (e.g. 4K UHD, 4K UHD S or WQXGA on a WQXGA UDX)</li> <li>Digital Zoom (Enabled status and factor)</li> <li>Digital Shift (Enabled Status, X and Y)</li> </ul>
PQ	<ul style="list-style-type: none"> <li>Screen luminance</li> <li>HDR boost value</li> </ul>
Realcolor	<ul style="list-style-type: none"> <li>Brilliant Color mode</li> <li>P7 desired values</li> <li>P7 measured values</li> </ul>
Installation	<ul style="list-style-type: none"> <li>Lens parameters, if available (only valid if recalled with same lens)                             <ul style="list-style-type: none"> <li>Iris</li> <li>Focus</li> <li>Zoom</li> </ul> </li> <li>Lens shift (Vertical / Horizontal)</li> </ul>

Area of interest	Settings
	<ul style="list-style-type: none"> <li>• Motorized Frame parameters, if connected               <ul style="list-style-type: none"> <li>- Rotate</li> <li>- Tilt</li> <li>- Skew</li> </ul> </li> <li>• Shutter position</li> <li>• Image orientation</li> <li>• Scaling mode</li> </ul>
Warp settings	Note: Only file-based warp supported via profiles <ul style="list-style-type: none"> <li>• Warp enabled status</li> <li>• Selected warp file</li> <li>• Transport delay</li> </ul>
Blend	<ul style="list-style-type: none"> <li>• Mask blend               <ul style="list-style-type: none"> <li>- Enabled status</li> <li>- Start and Width for each side</li> </ul> </li> <li>• File blend               <ul style="list-style-type: none"> <li>- Enabled status</li> <li>- Selected files</li> </ul> </li> <li>• S-curve ("gamma")</li> </ul>
Black Level	<ul style="list-style-type: none"> <li>• Mask Black level               <ul style="list-style-type: none"> <li>- Enabled status</li> <li>- Width for each side</li> </ul> </li> <li>• File Black level               <ul style="list-style-type: none"> <li>- Enabled status</li> <li>- Selected file</li> </ul> </li> <li>• R/G/B gain values</li> </ul>
Illumination	<ul style="list-style-type: none"> <li>• Illumination power for each source</li> <li>• CLO enabled status</li> <li>• CLO setpoint</li> </ul>
Display	<ul style="list-style-type: none"> <li>• Display mode (ActiveStereo, AutoStereo or Mono)</li> <li>• 3D settings               <ul style="list-style-type: none"> <li>- Dark time value</li> <li>- Swap Frame Pair On/Off</li> <li>- Sync Delay value</li> <li>- Sync Delay Invert On/Off</li> </ul> </li> </ul>

## 4.3 Create new profile

1. Adjust the necessary projector set up values for the actual user case as described in the specific topics in this manual.
2. Enter the menu *Profiles*

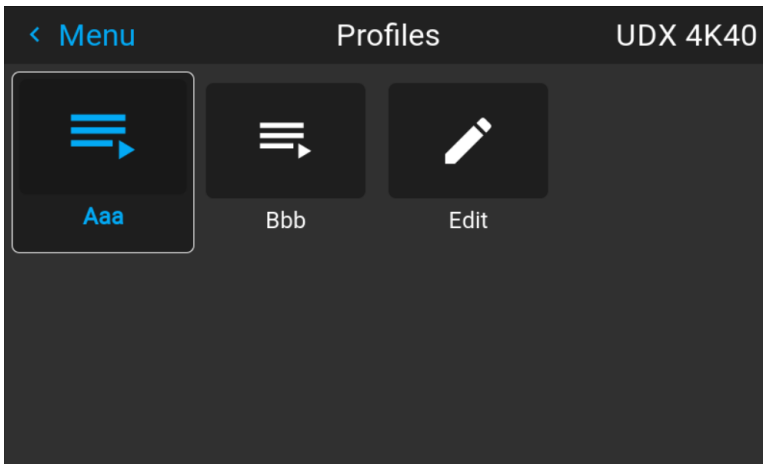

Image 4–2

3. Select the *Edit* button

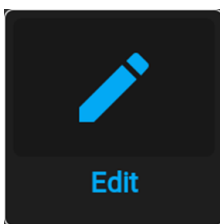

Image 4–3

The Profile edit menu shows up.

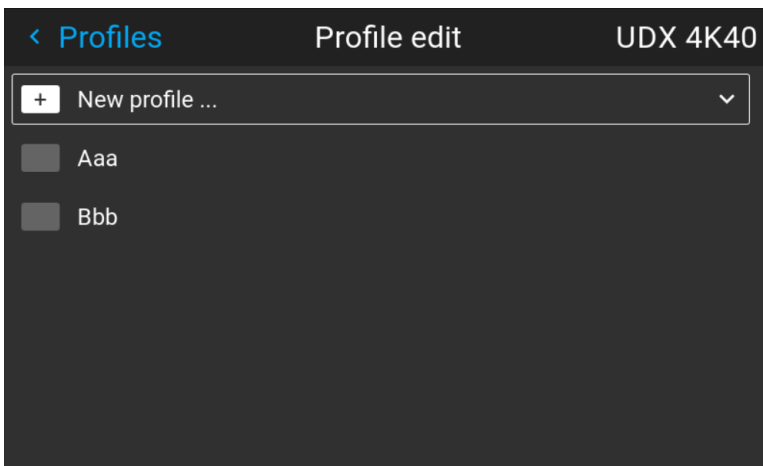

Image 4–4

4. Select New profile

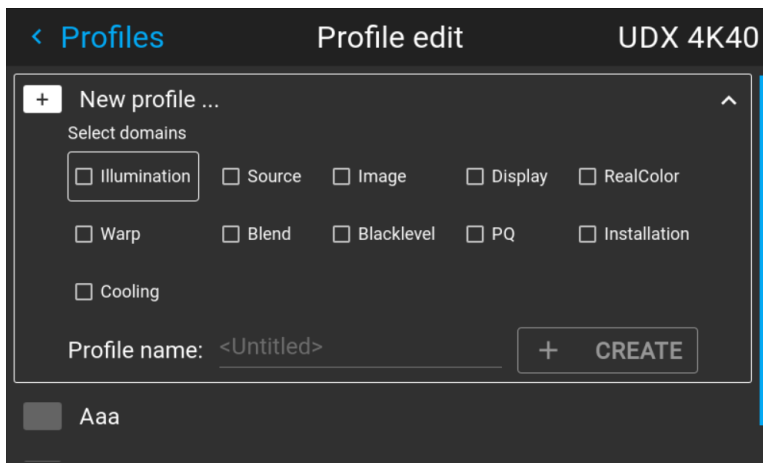

Image 4–5

5. Enter a suitable name for this profile via the pop up keyboard (arrow keys and OK (✓) to select). End the name entry by selecting the “return” key on the pop up keyboard.
6. Select the “Assign to preset slot”. A drop down menu will show up, select the preferred value.
 

*Note:* The function “**Assign to preset slot**” enables a shortcut to the actual profile from the remote control. If assigned preset slot are set to 1, this profile can be recalled by pressing the key MACRO and then 01 on the remote control. It is not a requirement to use this function, just an option.

*Note:* The maximum number of profile presets is 30.
7. Select the domains in the menu that shall be stored in the profile.

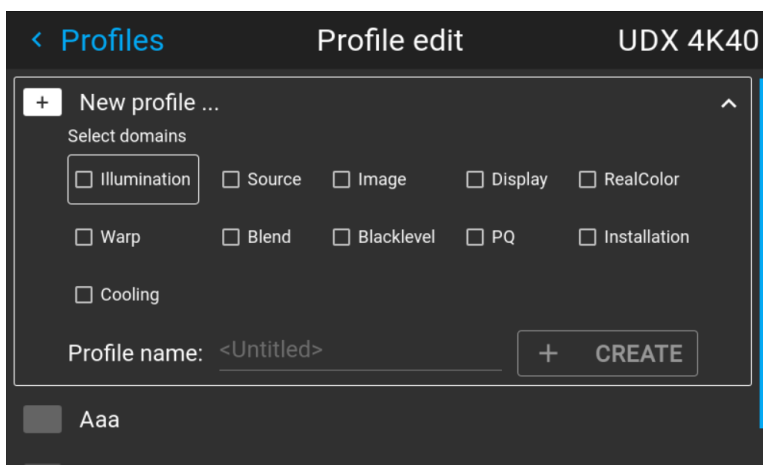

Image 4–6 Select domains

8. Select “Profile name”. A keyboard will show up, and enter a proper name for the profile.
9. Select “create” and confirm by the OK button.
 

The new profile is now created and saved.
10. Repeat step 1 to 6 for creating of more profiles.

### Recall a profile.

1. Enter the *Menu/ Profile*

The stored profiles will be visible in the menu. Select the actual profile.

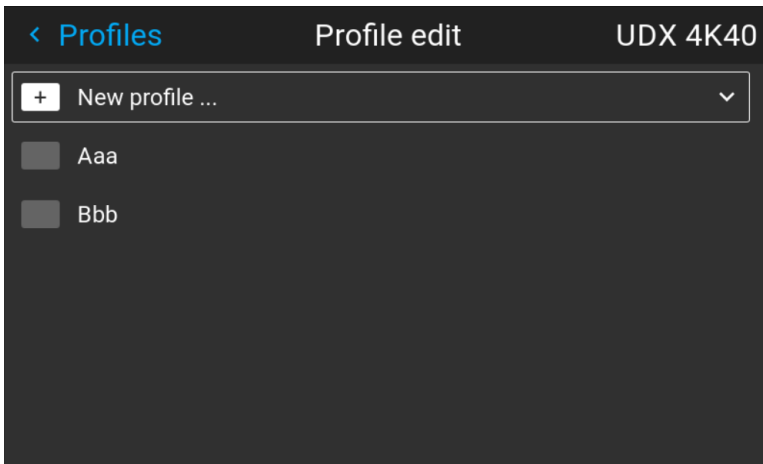

Image 4–7

or

Select the numeric shortcut from the remote control.

### Edit a profile

1. Enter the *Menu/Profiles/Edit*  
Select the profile to be edited.
2. Set, or change the “Assign to preset” number, or delete the actual profile. It is not possible to add or remove selected features in an stored profile. Must then be deleted, and a new profile must be created.

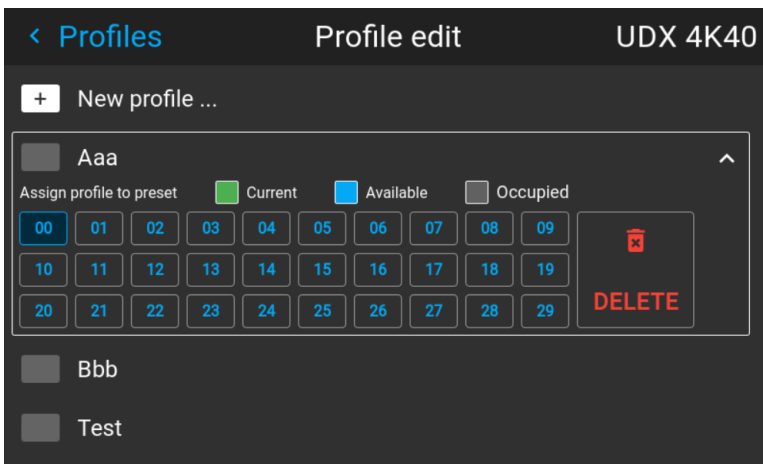

Image 4–8

# Upgrade projector firmware

# 5

5.1	Upgrade procedure.....	48
-----	------------------------	----

## 5.1 Upgrade procedure



**CAUTION:** Do NOT power down or remove mains power supply when an upgrade is in progress.



Once initiated, the upgrade procedure can take up to 20 minutes to complete.  
The LCD display will show the progression and status of the upgrade during the process.

### Update

- Go to [www.barco.com](http://www.barco.com) and select your product. All available firmware downloads are filed under the Technical Downloads tab.
- Download the firmware. Extract and save the file to a USB stick with FAT file system. Use the eject function on your PC to safely remove the device from the computer.
- Place the projector in Ready mode (status indicator is steady White).
- Insert the USB Stick in to the rear USB port on the projector.  
After a few seconds, the status indicator will flash. (rate: 3 Hz/180 FPM). This signals that the upgrade is in progress. If the upgrade file is corrupt or invalid, the status indicator will turn red and the upgrade process will stop. Note! The upgrade will not be installed in this instance, and the upgrade process must be restarted with a full and correct file. The projector may restart several times during the upgrade process
- The LCD display will show the progress of the update procedure, and also when the USB stick can be removed. The projector will return to standby mode (status indicator is steady amber) once the upgrade is completed successfully.



# User maintenance — Cleaning the projector

# 6

6.1	Projector lenses.....	50
6.2	Projector cabinet .....	50

## 6.1 Projector lenses

### General guidelines for cleaning projector lenses

Blow off dust with clean compressed air (or pressurized air cans) .

Use lens cleaner and a clean lens cleaning cloth to remove the dust and contamination.

Wipe in broad strokes, in one direction only.

Warning: Do not wipe back and forwards across the lens surface as this tends to grind dirt into the coating.

Use a dry clean lens cleaning cloth to remove left liquid or stripes. Polish with small circles.

If there are still fingerprints on the surface, repeat with lens cleaner and a clean lens cleaning cloth, then polish again with a dry cloth.



If smears occur when cleaning lenses, replace the cloth. Smears are the first indication of a dirty cloth.

## 6.2 Projector cabinet



**WARNING:** Always disconnect the projector from the mains power net before attempting to clean the projector cabinet.

### General guidelines for cleaning the projector cabinet (exterior only)

Clean the housing of the projector with a damp cloth. Stubborn stains may be removed with a cloth lightly dampened with a mild detergent solution.

# Index

## C

- China RoHS compliance 13
- Clean
  - lenses 50
- Cleaning
  - cabinet 50
  - chassis 50
  - exterior 50
  - lenses 49
  - projector 49
- Connections 32
  - making 31
- Connector 32
  - specifications 32
- Connector panel 29
- Consumables 19
- Control Interfaces 34
- Controlling the projector 29
- Create profile 43

## D

- Disposal 12

## E

- Enable / Disable Remote Control 27

## F

- Function
  - RGB button 27
  - RGB filter 27

## G

- General considerations 8
- Getting started
  - Projector address 28
  - Terminology overview 26

## H

- HDBaseT 33
- HDMI 33

## I

- Important safety instructions 8
- Importer 15

## K

- keypad 22

## L

- LAN/Ethernet 34
- LCD 19
- LCD functionality in Ready Mode 22
- LCD information mode. 20
- LCD Panel 19
- LFM 19
- local
  - keypad 22
- Location of labels 12
- Location of the main exterior components. 18

## O

- On Screen Display 38
- OSD 38
- OSD Menu Mode. 22

## P

- Power
  - down 31
  - modes 31, 37
  - up 31
- Power down 35

- Power mode transitions 36
  - General 36
  - Going from ECO to ON 37
  - Going from ON to READY 37
  - Going from READY to ECO standby 37
  - Going from READY to ON 36
  - Plugging power cord 36
  - Power on projector 36
- Power on 35
- Power on button 19
- Power up 35
- Product Info 15
- Production Address 15
- Profile setup matrix
  - Profile 42
- Profiles
  - Introduction 42
  - Preset variables 41
- Projector
  - Accessories 17
  - cleaning 49
  - Consumables 17
  - Low Frequency Maintenance 17
  - Main Components 17
  - power down 31
  - power modes 31
  - power up 31
- Projector address 28
  - Controlling 29
- Projector source and control connections 32

## R

- RCU 24
  - Battery
    - Installation 24
  - Functionality overview 26
  - Protocol setup 25
- RCU on/off 27
- RS-232 34

## S

- Safety
  - Environment 7
- Safety symbols 11
- Service and maintenance 19
- Settings
  - customize 37
- Shortcut buttons 23
- Shortcut keys 31
- Signals 32
- Specifications 32
- Start up 31
- Statement 15

## T

- Taiwan RoHS compliance 14
- Touch panel 20
- Turkey RoHS compliance 12

## U

- Upgrade procedure 48
- Upgrade projector firmware 47
- USB-A 35
- User interface 38

## W

- Wake On LAN (WOL) 37
- Wired RC connection 28



